

Brondell®

Nebia Merced Four-Setting Commercial Handshower, 1.5 gpm

Model: NE65-HS

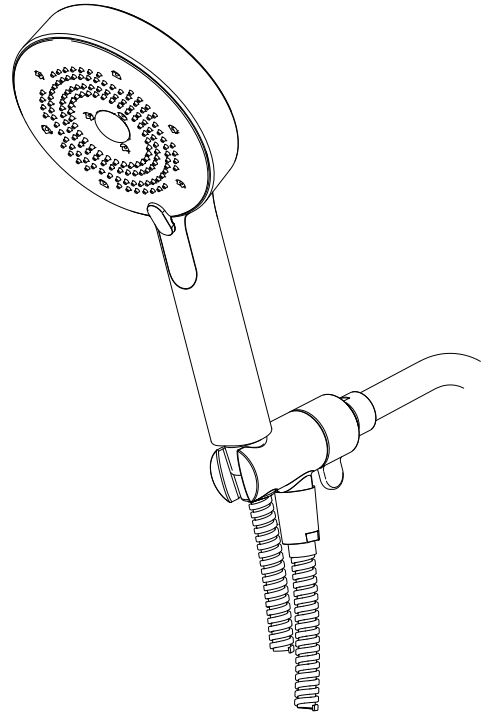
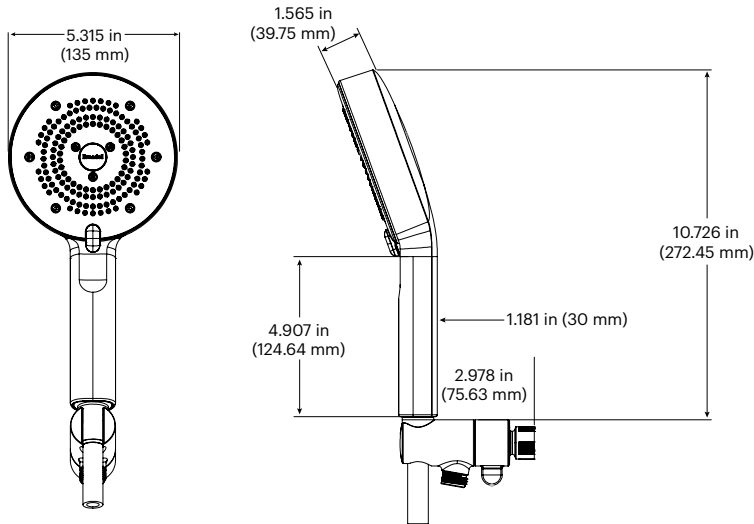

Features

Up to 40% water savings compared to a standard 2.5 gpm shower

Up to 75% more force than standard showerheads*

Four spray modes: Hard Spray, Power Spray, Focused Spray, Angel Hair Spray

Wide, 5.3" diameter showerhead

Easy adjustment with SureGrip™ tab

60" flexible, stainless steel hose

Brass shower ball stands up to commercial use

Universally compatible

Limited 5-year commercial warranty

*Compared to the minimum EPA WaterSense performance specifications for showerheads.

Technical Specifications

Dimensions (L x W x H)	10.75" x 5.3" x 1.25" / 27.3 cm x 13.46 cm x 3.8 cm
Weight	1.27 lbs / .58 kg
Supply Water Pressure	20-80 psi / 1.4-5.5 bar
Flow Rate	Max 1.5 gpm at 80 psi
Thread Size	0.5" IPS / G 0.5"
Hose Length	60" / 152.4 cm



NOTE: Designed and manufactured to comply with the applicable requirements of WaterSense®. ASME112.18.1/CSA B-125.1, ASSE 1014 and all applicable specifications referenced therein

#24NE65-HS_1115

Brondell®
Feels better already.

Brondell, Inc.
PO Box 470085
San Francisco, CA 94147
brondell.com